

DO12R

Module with 12 Relay Outputs

Data Sheet

Doc: 40405 v1.10





INTRODUCTION

Before using the LB2 Series I/O Modules, read the LB2 User manual.

The Brodersen LB2 modules can be used with the RTU32N and RTU32M series products. The I/O modules are in two parts, a bottom part containing the backplane bus, and a top part containing the I/O board and logic. All LB2 I/O modules are hot pluggable and equipped with a 200 MHz processor to handle filtering, de-bouncing and logic processing of I/O.

Module firmware updates are managed by the RTU using Brodersen Worksuite. Use only genuine Brodersen bus cables for connection to Brodersen RTUs and extension of I/O module blocks. The LB2 connection cables are made to handle the power and shielding requirements of the LB2 bus communications. The maximum overall length of complete system is 30m. Each I/O module & Power supply module is calculated as 2cm. The cables are as their length indicates, e.g. UCC-610/100 cable is 100 cm.

The maximum number of I/O modules on one LB2 Bus is 60.

Cable ordering codes:

- UCC-610/25 25cm LB2 Cable
- UCC-610/50 50cm LB2 Cable
- UCC-610/100 100cm LB2 Cable
- UCC-610/200 200cm LB2 Cable

POWER SUPPLY MODULE BACKPLANE PART

Description	Part Nr.
BUS module for IOs, Start	BB21A
BUS module for IOs, Middle	BB21B
BUS module for IOs, Extension	BB21C

VERSIONS / ORDERING CODES

Hardware basic version:

Order code: DO12R

I/O INTERFACE

Connectors relay output:

2x 12 way 3.5mm pluggable spring clamp connectors. The maximum conductor cross sectional area is AWG 16 (1.3mm²). The wire conductor type should be Copper and it must meet the minimum temperature criteria of 105°C.

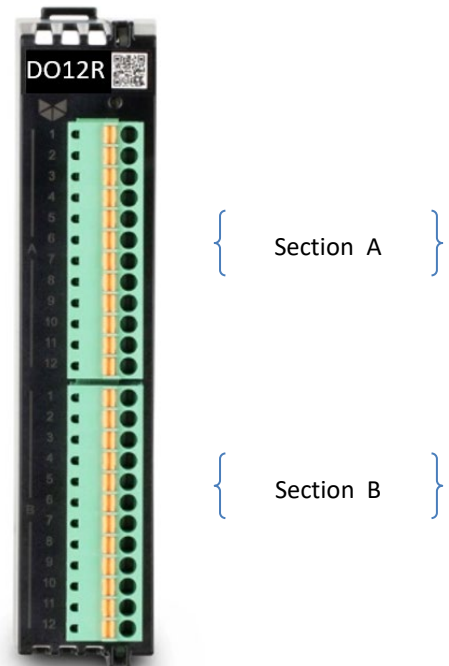

TERMINALS LAYOUT

Connector top section A:

- Pin 1...2: Relay output 0 contact, NO.
- Pin 3...4: Relay output 1 contact, NO.
- Pin 5...6: Relay output 2 contact, NO.
- Pin 7...8: Relay output 3 contact, NO.
- Pin 9...10: Relay output 4 contact, NO.
- Pin 11...12: Relay output 5 contact, NO.

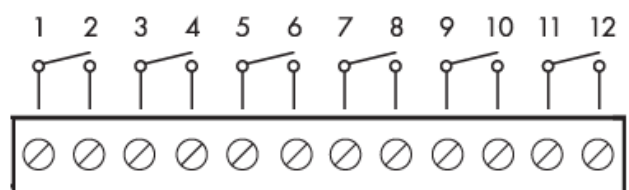

Electrical diagram Relay output



Connector bottom section B:

- Pin 1...2: Relay output 0 contact, NO.
- Pin 3...4: Relay output 1 contact, NO.
- Pin 5...6: Relay output 2 contact, NO.
- Pin 7...8: Relay output 3 contact, NO.
- Pin 9...10: Relay output 4 contact, NO.
- Pin 11...12: Relay output 5 contact, NO.

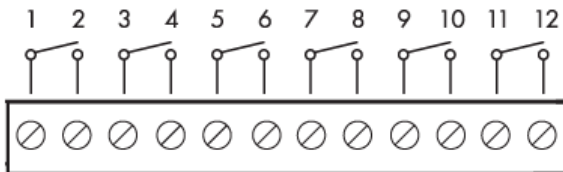

Electrical diagram Relay output

ELECTRICAL

Power consumption (from backplane bus):

- Current consumption (min*): 25mA @ 12V
- Current consumption (max**): 150mA @ 12V
- Power consumption (min): 300mW
- Power consumption (max): 1.8W

* All relay outputs are de-activated. About 10mA per each activated relay will be added to this value.

** All relay outputs are activated.

Relay output:

12 mechanical non latching relay outputs, SPST, Relay output: potential free contact SPST (NO). Each channel is galvanically isolated from each other and also from electronics.

Load voltage:

Max 250 VAC, 125 VDC

Load current:

- 5A @ 30VDC/250VAC (resistive load)
- 2A @ 30VDC/250VAC (cos ϕ = 0.4, L/R = 7ms)

Max. switching Power:

1250VA / 150W

Output delay:

Typical 5ms

Isolation:

3Kv output to electronics, 1 minute.

Over voltage category II (OV II):

250VAC/VDC

MAXIMUM SWITCHING POWER

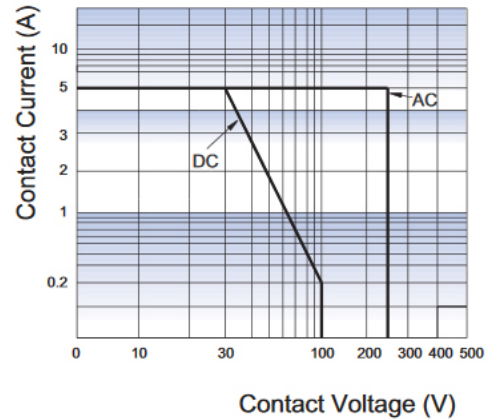

Note/Remarks:

When inductive or DC loads are switched the load capacity of the output relay is reduced and it is recommended to use a RC network.

MECHANICAL

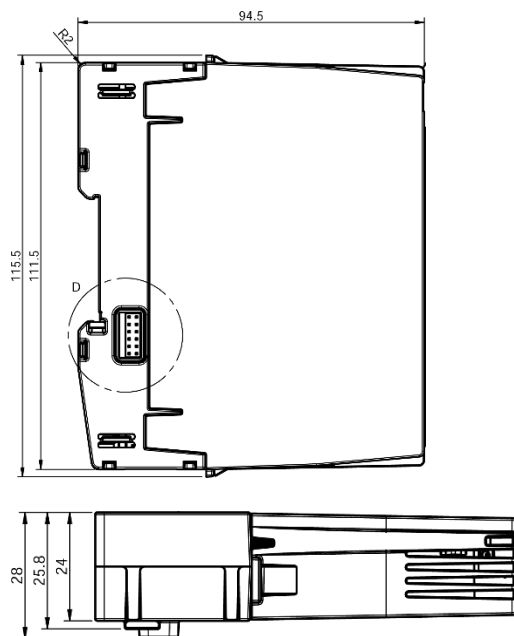

Mounting	DIN 35
Width	24 mm
Height	111.5 mm
Depth	94.5 mm
Weight	102 grams



ENVIRONMENTAL CONDITIONS

Ambient operating temperature range	-25°C to +75°C
Ambient storage temperature range	-40°C to +85°C
Marked degree of protection	IP20
Humidity	0...99.8%
Ventilation Restrictions	No
Pollution degree	2

STANDARDS

EMC:

- **IEC 61000-6-2:** EMC - Immunity standard for industrial environments
- **IEC 61000-6-4:** EMC - Emission standard for industrial environments
- **IEC 50121-4:** Railway applications - EMC - Emission and immunity of the signalling and telecommunications apparatus

Safety:

- **IEC 60950-1:** Safety requirements for Information technology equipment
- **IEC 61010-1:** Safety requirements for electrical equipment for measurement, control, and laboratory use

Environmental:

- **IEC 60068-2-1:** Environmental testing - Cold
- **IEC 60068-2-2:** Environmental testing - Dry heat
- **IEC 60068-2-30:** Environmental testing - Damp heat, cyclic (12 h + 12 h cycle)
- **IEC 60068-2-78:** Environmental testing - Damp heat, steady state
- **IEC 60068-2-6:** Environmental testing - Vibration (sinusoidal)
- **IEC 60068-2-27:** Environmental testing - Shock

MODULE LED STATUS

A dual color (red/yellow) LED is provided on the module to indicate the module status. Yellow indicates the module mode / state and red indicates module error or warnings (according to the table below):

Status	Yellow	Red
Normal operating	ON	OFF
Communication timeout	Blinking	OFF
Module is not configured / wrong configuration	Single flashing	OFF
Module is configured but is in stopped mode (ready for being started)	Double flashing	OFF
Module is in firmware update mode	Quadruple flashing	OFF
Communication error	N/A	Blinking
Communication warning	N/A	Single flashing
Corrupted module info in EEPROM	N/A	Flickering
Hardware fatal error	OFF	ON
No module power	OFF	OFF

Each pattern / color will operate in 2 sec duty cycles. When the red LED is inactive (off), only the 2 sec yellow duty cycle will operate (yellow is always active). When the red LED is active, a switch between 2 sec yellow, and 2 sec red patterns will occur.

SAFETY PRECAUTIONS

- Follow the national safety regulation (IEC 61010-1) 
- Only skilled person is allowed to install and operate the modules.
- Disconnect the input supply while working with relay module.
- Modules can only be mounted in an end-use enclosure which provides protection against fire, electrical and mechanical hazards.
- If the equipment is used in a manner not specified by the manufacturer, the protection provided by the equipment may be impaired.